

5113560C

Lire attentivement cette notice avant toute utilisation.

SOMFY SAS, 50 avenue du Nouveau Monde 74300 CLUSES - FRANCE - & (33) 4 50 96 70 00 - capital 20.000.000 € - RCS Bonneville 303.970.230

Gamme LT80 S - LT80 S CSI

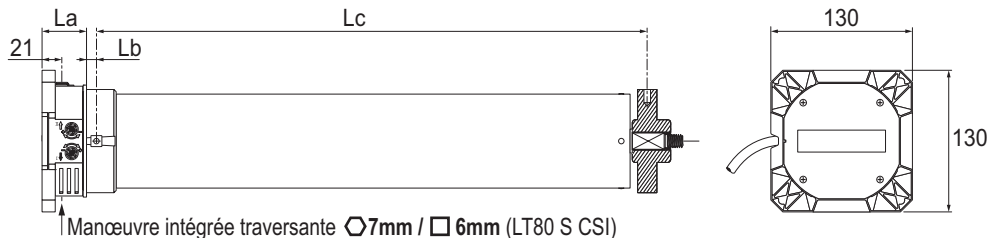

COUPLE (N.m)	La (mm)		Lb (mm)		Lc (mm)				DIAMETRE DE BASE (mm)	RAPPORT DE REDUCTION MANOEUVRE DE DEPANNAGE
	150	200	250	300	LT80 S		LT80 CSI			
150	43*	49**	8*	18**	609*	595**	659*	645**	94	190 / 1
200										
250										
300										

* Longueur avec adaptation $\varnothing < 119\text{mm}$ - ** Longueur avec adaptation $\varnothing > 119\text{mm}$

Accessoires

Support moteur

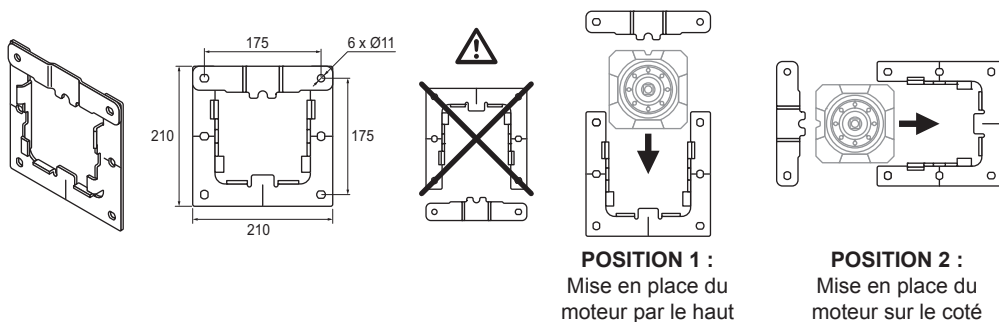

Accessoires de manœuvre de dépannage

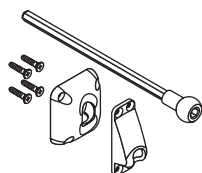

sortie invisible

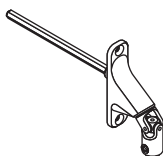

genouillère 90°

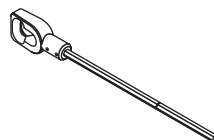

anneau

1 Montage des adaptations

Ø94



Ø94
9001297

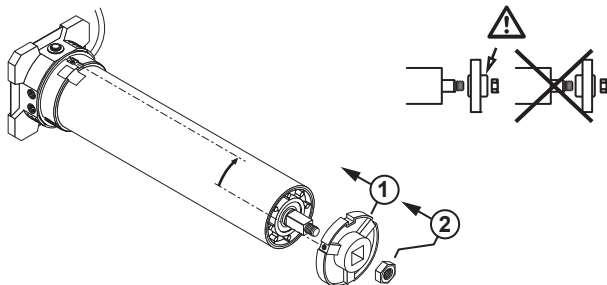

Ø97 - Ø100



Ø97
9001312



Ø100
9001313

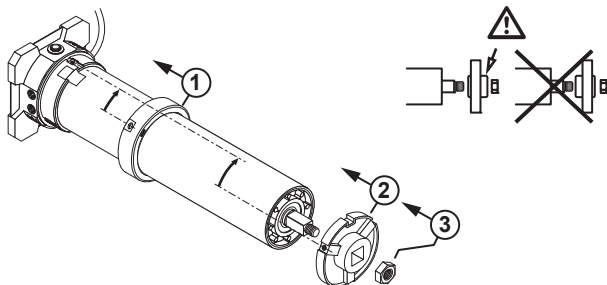

Ø119 - Ø124 - Ø127



Ø119
9013826

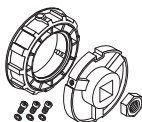

Ø124
9013824



Ø127
9013822

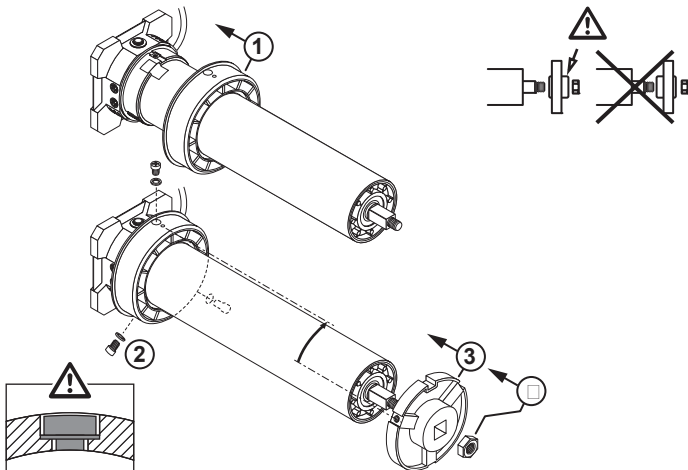

Ø131 - Ø133



Ø131 : 9013437
Ø133 : 9013438

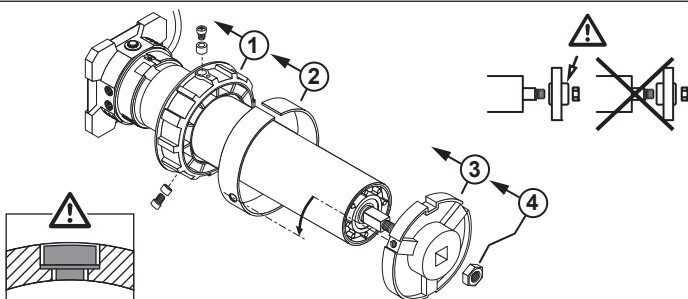

Ø149 - Ø152 - Ø158 - Ø160 - Ø168

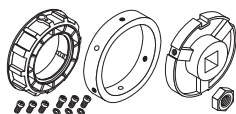

Ø149 : 9013439
 Ø152 : 9013525
 Ø158 : 9013526
 Ø160 : 9013527
 Ø168 : 9013528

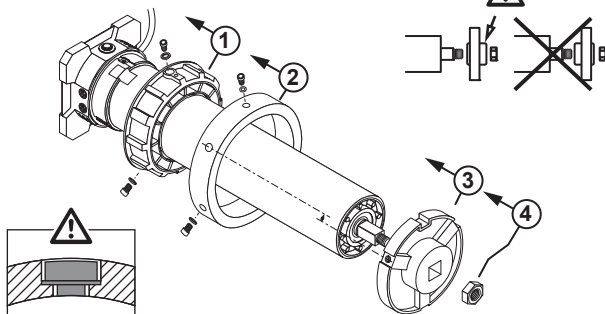

2 Montage du moteur dans le tube

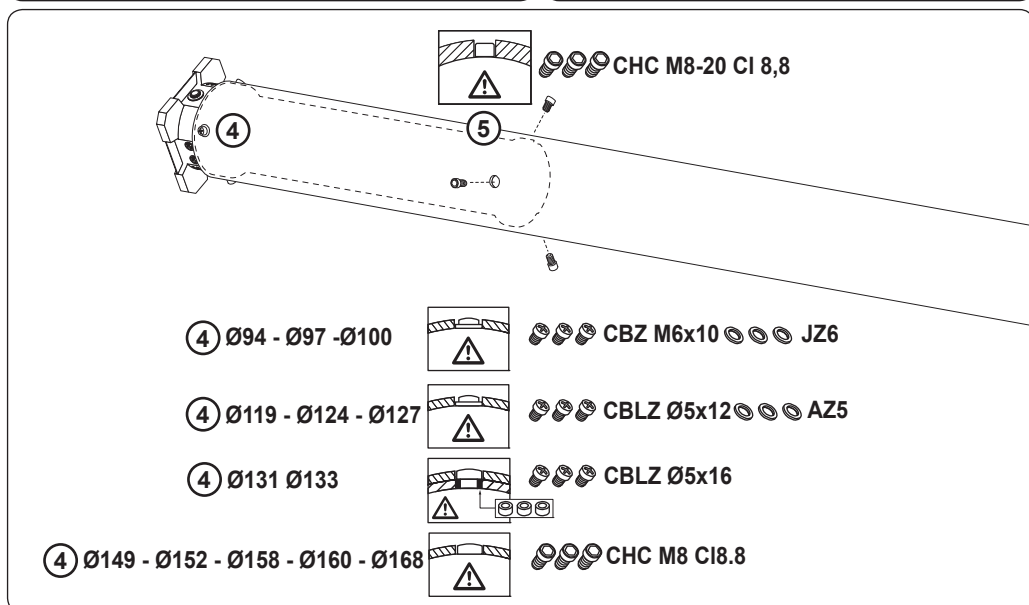
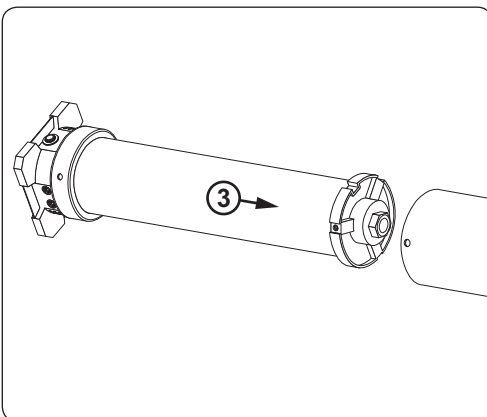
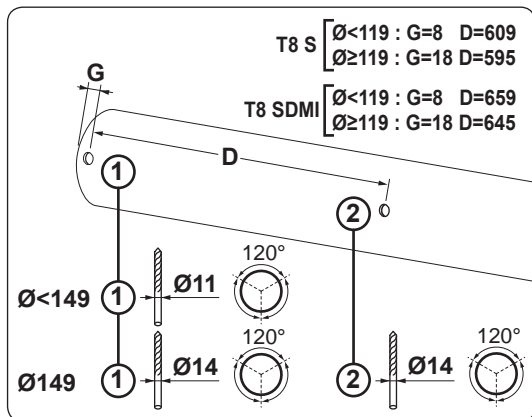

3 Montage du moteur

La tête moteur carrée permet la mise en place du moteur dans le support dans quatre positions différentes :

1. Réglage fin de course de face, manœuvre de dépannage verticale (permet un dépannage par anneau ou par genouillère) et câble d'alimentation à l'arrière.
2. Réglage fin de course arrière, manœuvre de dépannage verticale et câble d'alimentation à l'avant (idem cas 1).
3. Réglage fin de course dessous, manœuvre de dépannage horizontale (permet un dépannage par sortie de caisson 90°) et câble d'alimentation au dessus.
4. Réglage fin de course au dessus, manœuvre de dépannage horizontale et câble d'alimentation au dessous (idem cas 3)

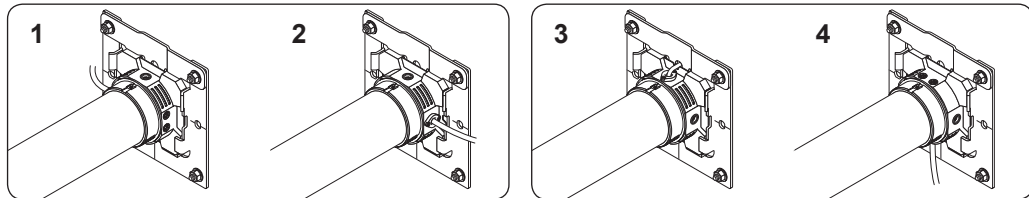

Intégration de l'axe motorisé "entre murs"

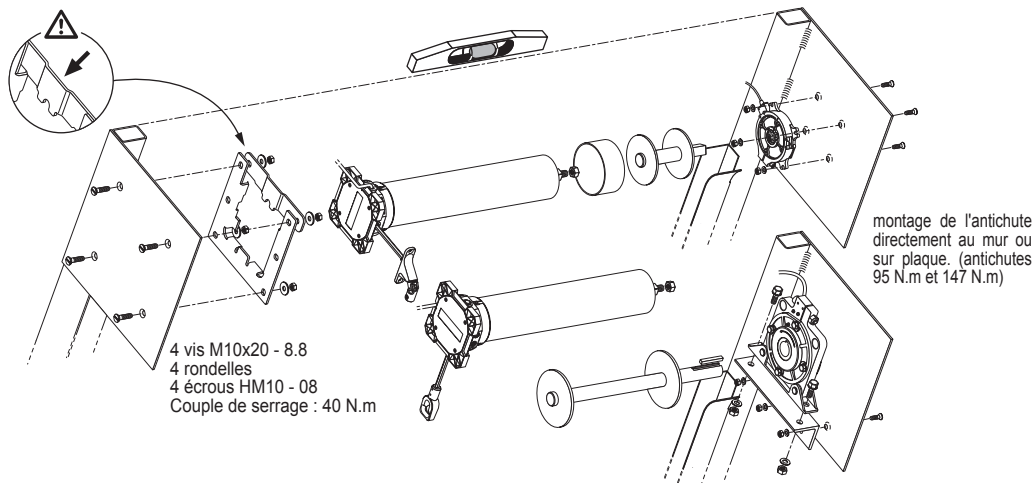

Intégration de l'axe motorisé en applique

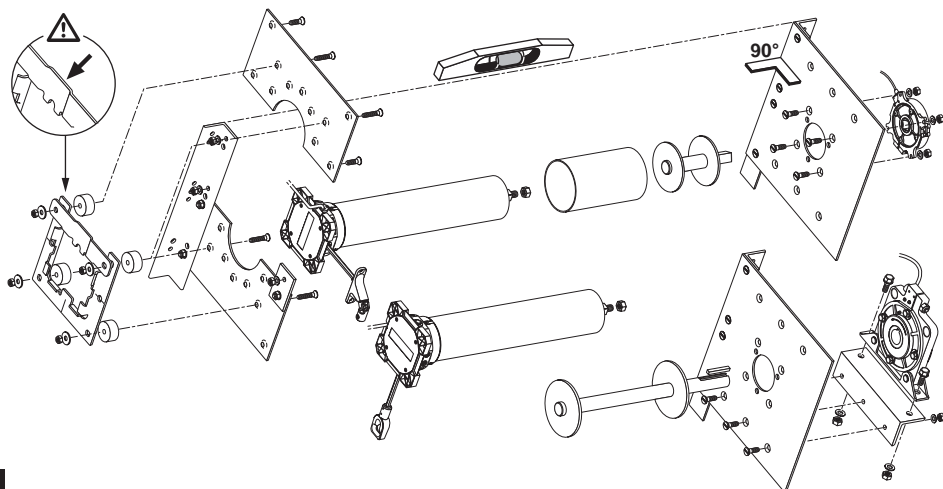

4 Systèmes de manœuvre de dépannage

- La manœuvre de dépannage est à entraînement direct, sans nécessité de tirer ou pousser.
- Il est possible et sans danger de tourner la manivelle même si le moteur est alimenté.

1. Manœuvre de dépannage horizontale

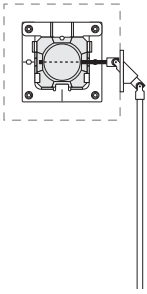

Par sortie de caisson 90°

2. Manœuvre de dépannage verticale

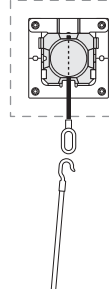

Par anneau

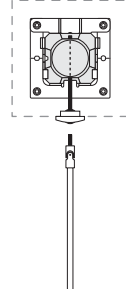

Par sortie de caisson invisible

5 Câblage

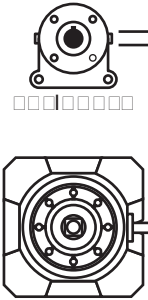

2	5	12
□□□□□□□□	⊕ PE	□□□□
□L□□	① N	□L□□
M□□□□□	② L	□□□□□
□□□□	③	□□□□

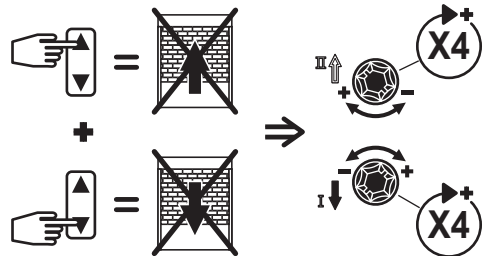
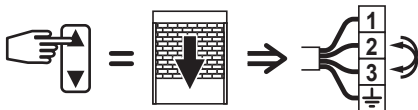
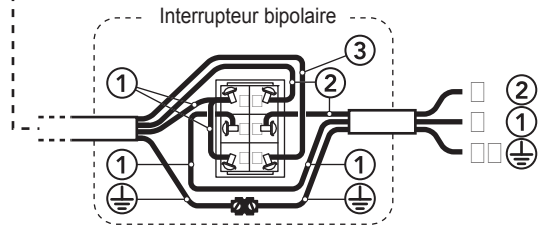
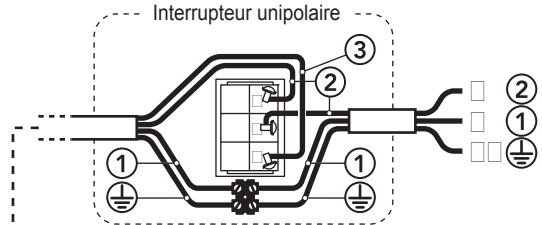

6 Identification des fin de courses

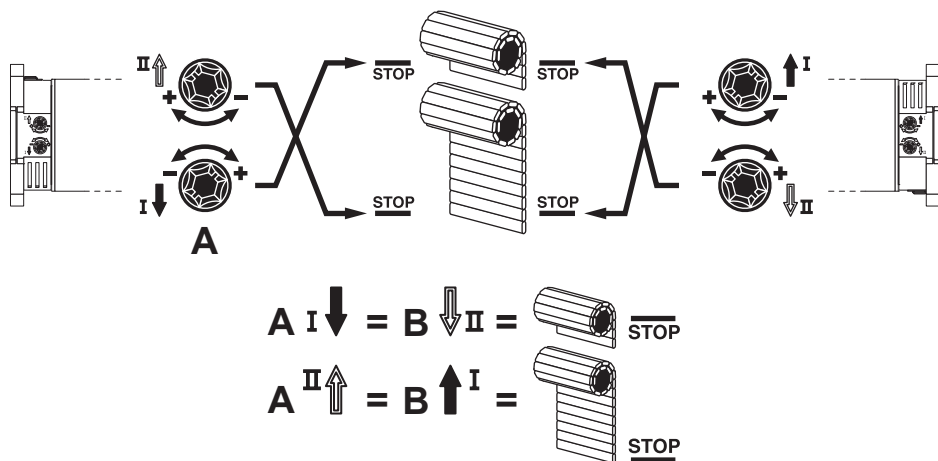
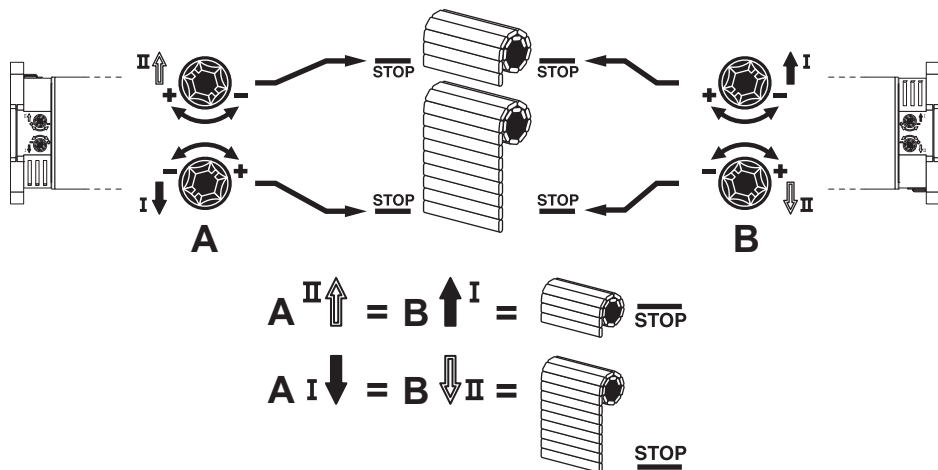

7 Réglage des fin de courses

1. Test

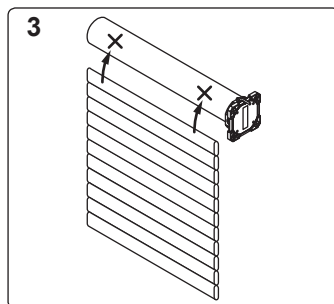
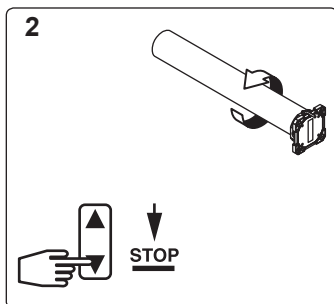
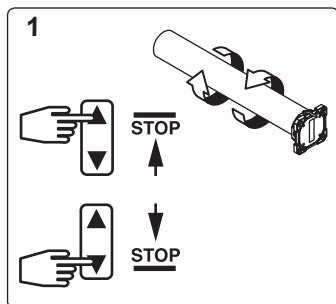

2. Réglage

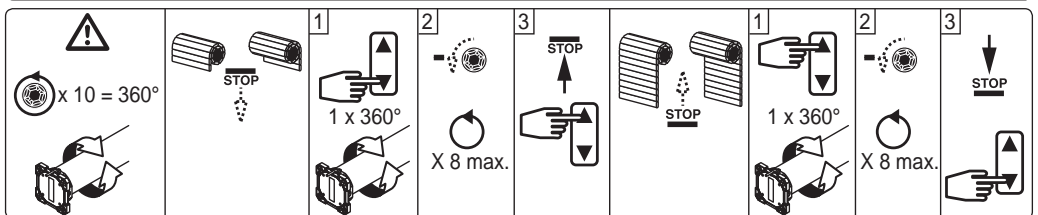
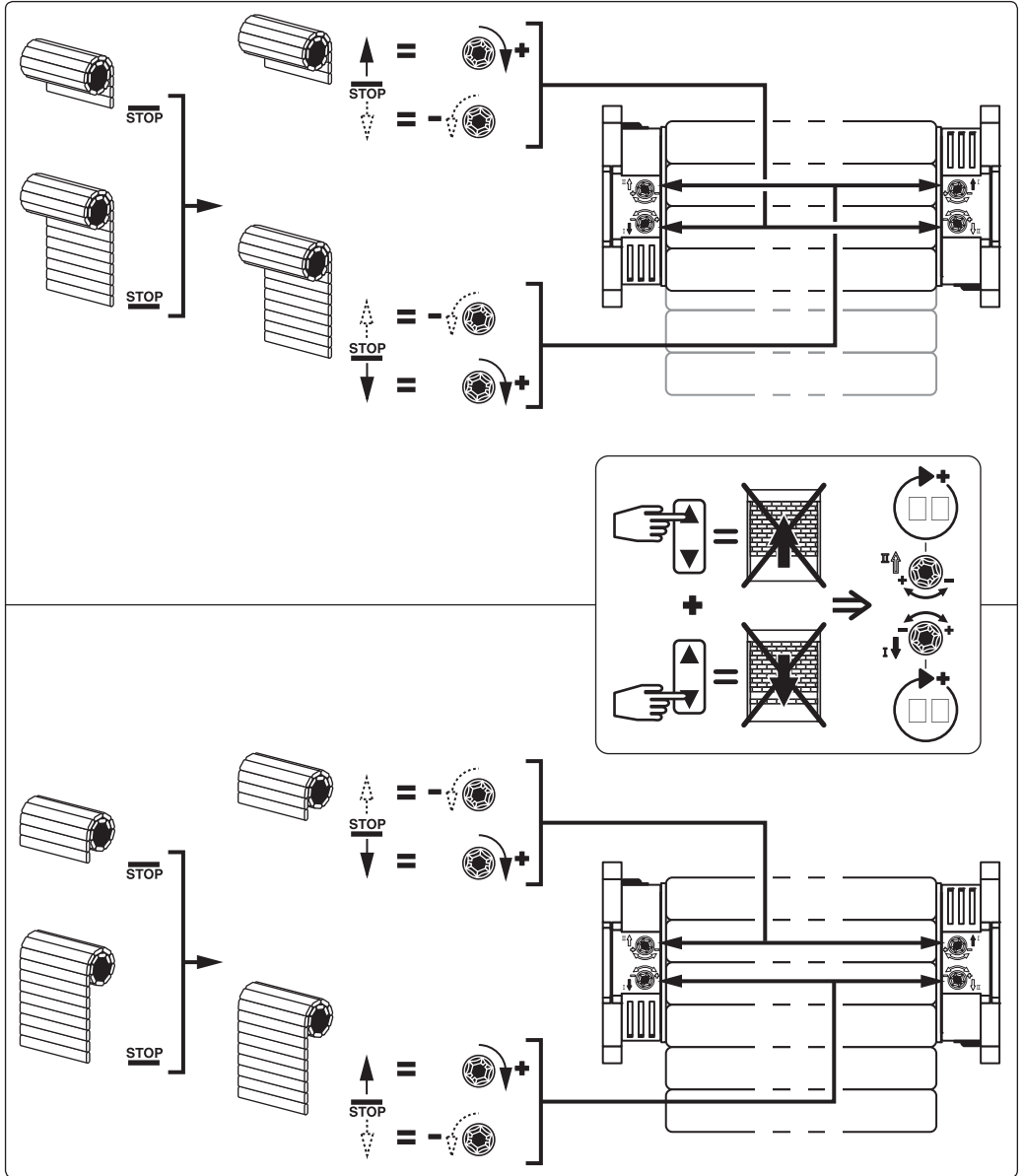



Dans le cas d'un moteur équipé d'une manoeuvre de dépannage, le sens de la montée doit systématiquement être indiqué à l'utilisateur final.

Si le moteur est combiné à un antichute, ce dernier doit être câblé avec le moteur.

Les caractéristiques de votre installation (tube, poids du rideau) doivent être conformes aux préconisations données dans les abaques d'utilisation.

Pour toute autre utilisation du moteur, hors fermeture, veuillez nous consulter.

LT80S SEL et LT80S CSI SEL

Moteurs avec Fin De Course de Sécurité. Voir étiquette sur la tête moteur.



En situation normale d'utilisation, si le moteur dépasse ses réglages initiaux et s'arrête sur son fin de course de sécurité, appelez votre personnel de maintenance pour inspection de l'installation.

5113560C

Read carefully these instructions before any use.

SOMFY SAS, 50 avenue du Nouveau Monde 74300 CLUSES - FRANCE - & (33) 4 50 96 70 00 - capital 20.000.000 € - RCS Bonneville 303.970.230

LT80 S - LT80 S CSI range

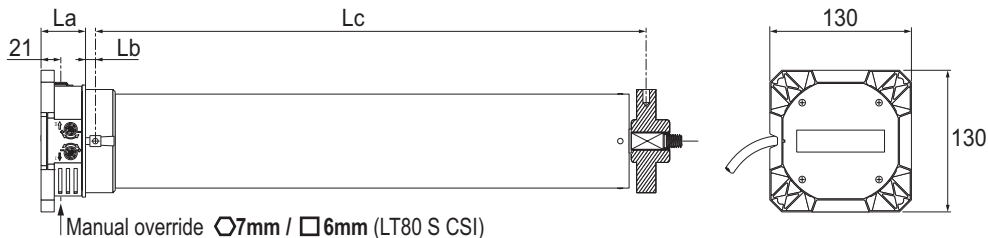

TORQUE (N.m)	La (mm)		Lb (mm)		Lc (mm)				BASE DIAMETER (mm)	MANUAL OVERRIDE REDUCTION RATIO
	150	200	250	300	LT80 S		LT80 S CSI			
	43*	49**	8*	18**	609*	595**	659*	645**	94	190 / 1

* Length with adaptors $\varnothing < 119\text{mm}$ - ** Length with adaptors $\varnothing > 119\text{mm}$

Accessories

Motor bracket

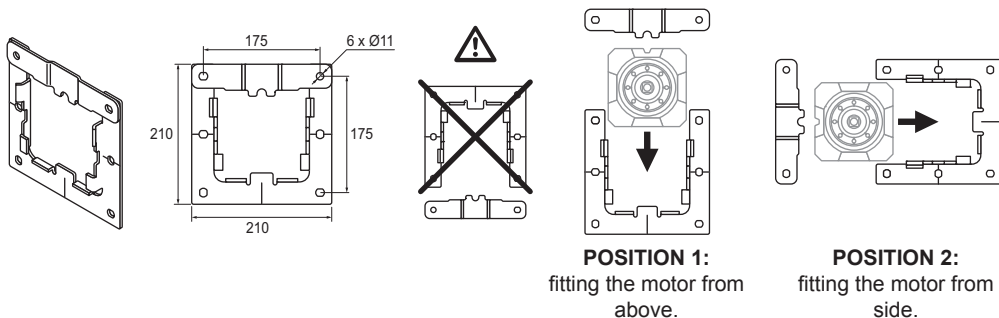

Accessories for manual override

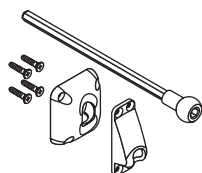

invisible box output

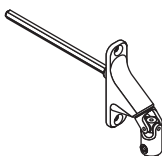

90° box joint

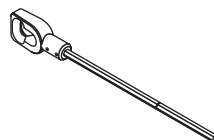

ring

1 Mounting the adaptors

Ø94



Ø94
9001297

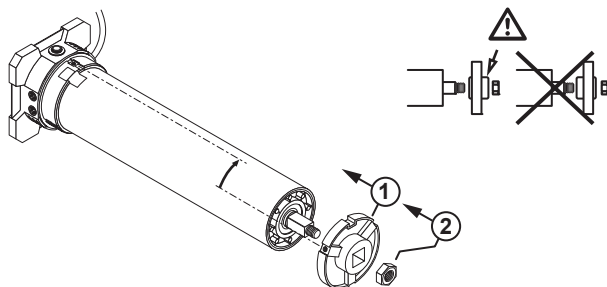

Ø97 - Ø100



Ø97
9001312



Ø100
9001313

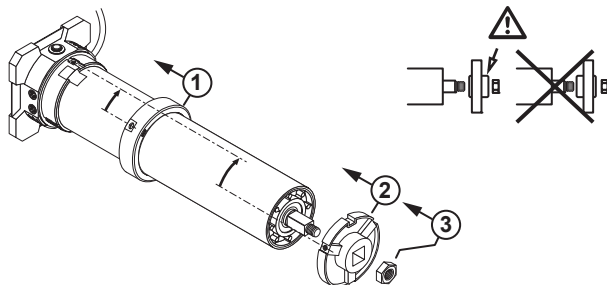

Ø119 - Ø124 - Ø127



Ø119
9013826



Ø124
9013824



Ø127
9013822

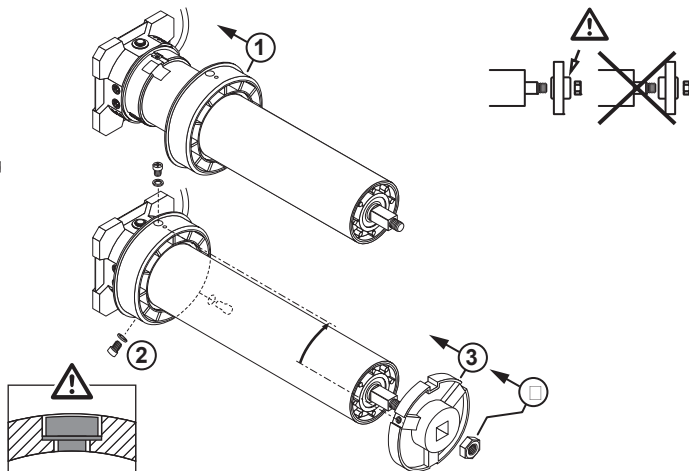

Ø131 - Ø133



Ø131 : 9013437
Ø133 : 9013438

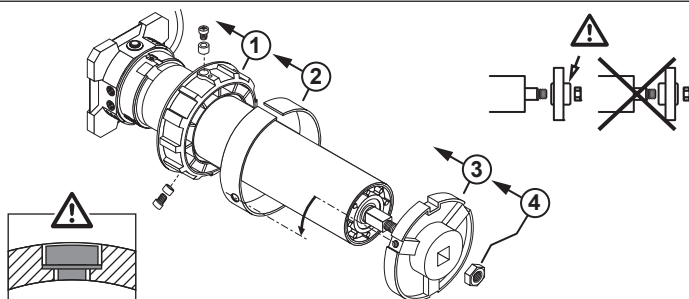

Ø149 - Ø152 - Ø158 - Ø160 - Ø168

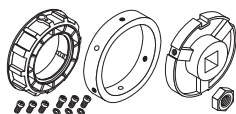

Ø149 : 9013439
 Ø152 : 9013525
 Ø158 : 9013526
 Ø160 : 9013527
 Ø168 : 9013528

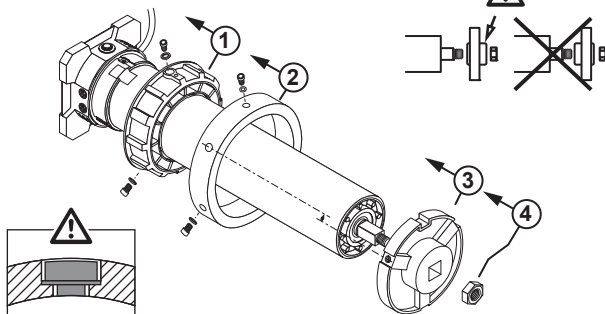

2 Fitting the motor in the tube

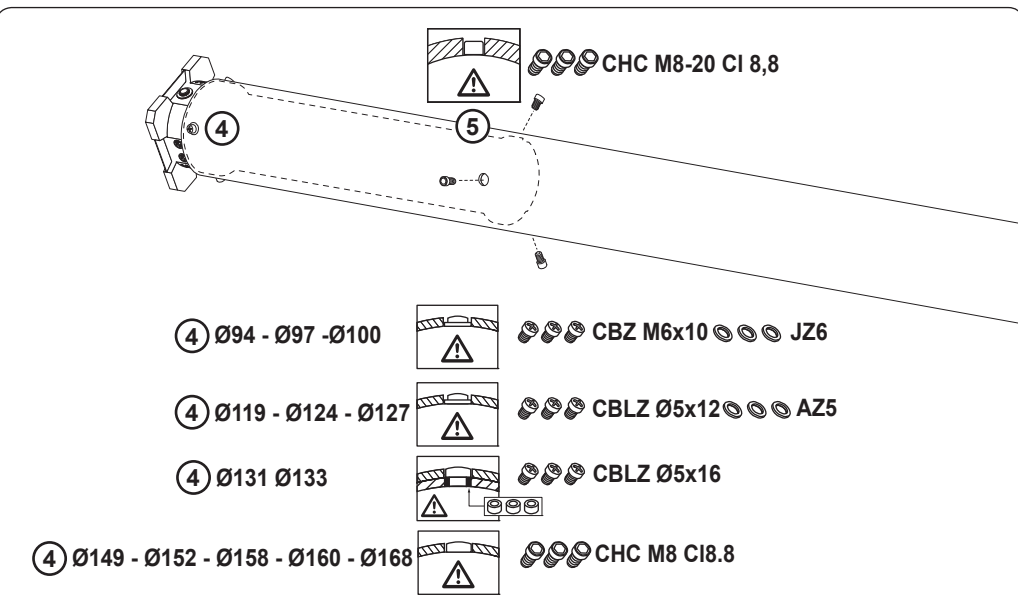
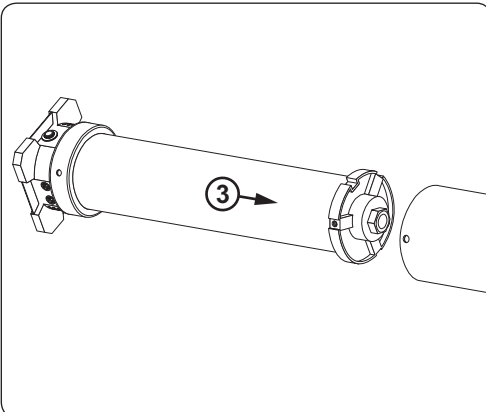
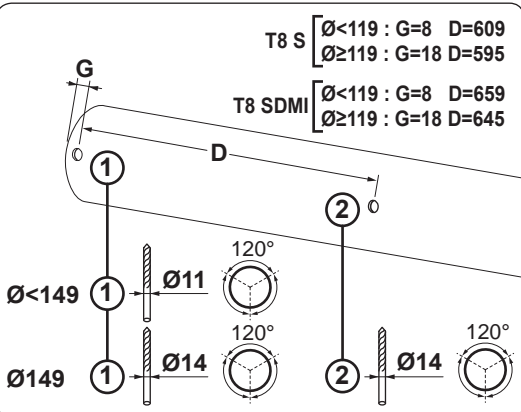

3 Installation

The square shaped motor head allows the mounting in four different positions:

1. Limit setting screws in front, vertical manual override (for ring or invisible box output) and power supply cable at rear.
2. Limit setting screws at rear, vertical manual override and power supply cable in front (same as 1).
3. Limit setting screws underside, horizontal manual override (for 90° box joint) and power supply cable above.
4. Limit setting screws above, horizontal manual override and power supply cable underside (same as 3)

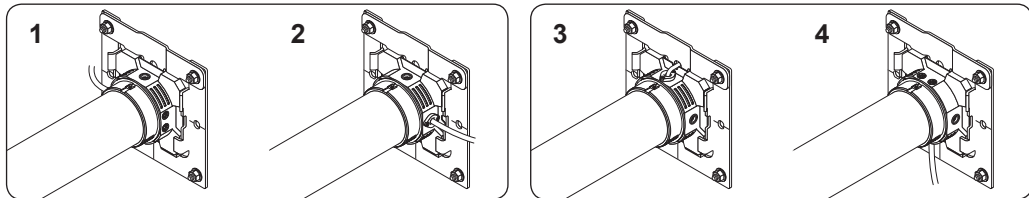

Installation "between walls"

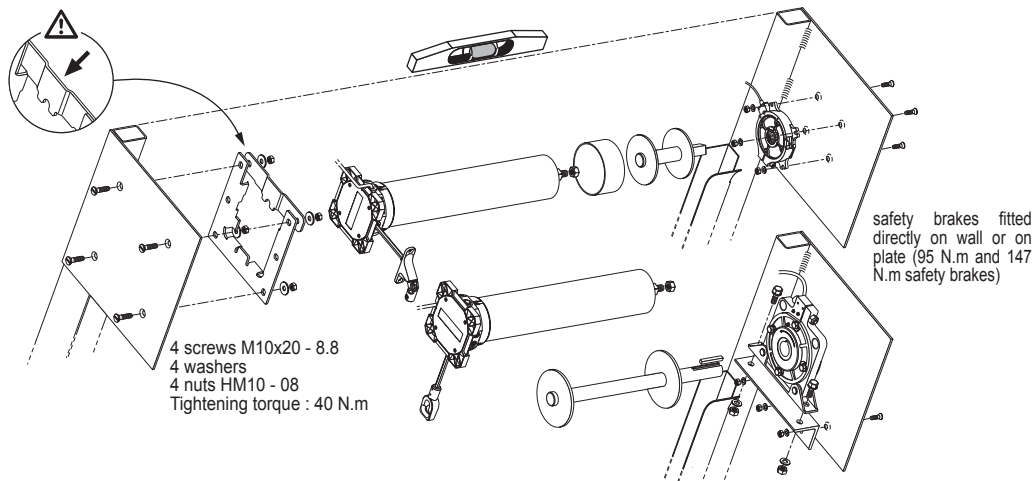

Mounting on plates

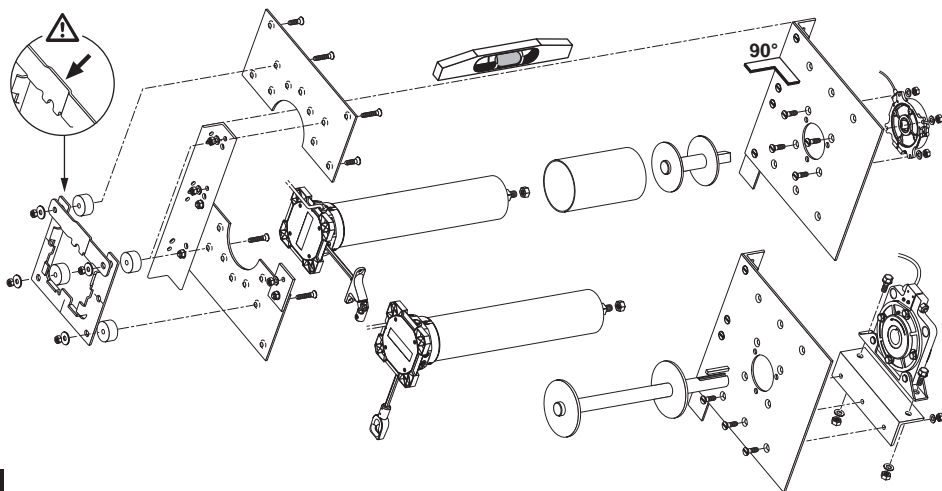

4 Manual override systems

- The manual override is direct drive, with no necessity to pull or push.
- It is possible and safe to crank even if the motor is energized.

1. Horizontal manual override

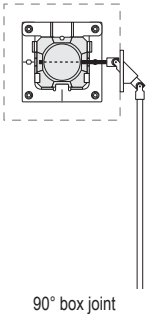

90° box joint

2. Vertical manual override

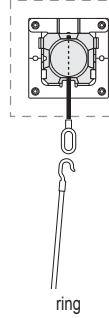

ring

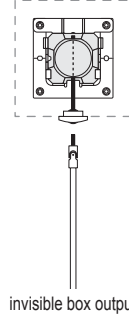

invisible box output

5 Wiring diagram

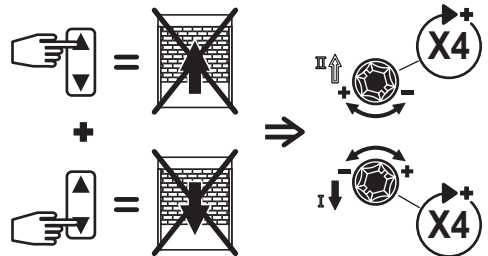
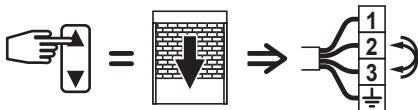
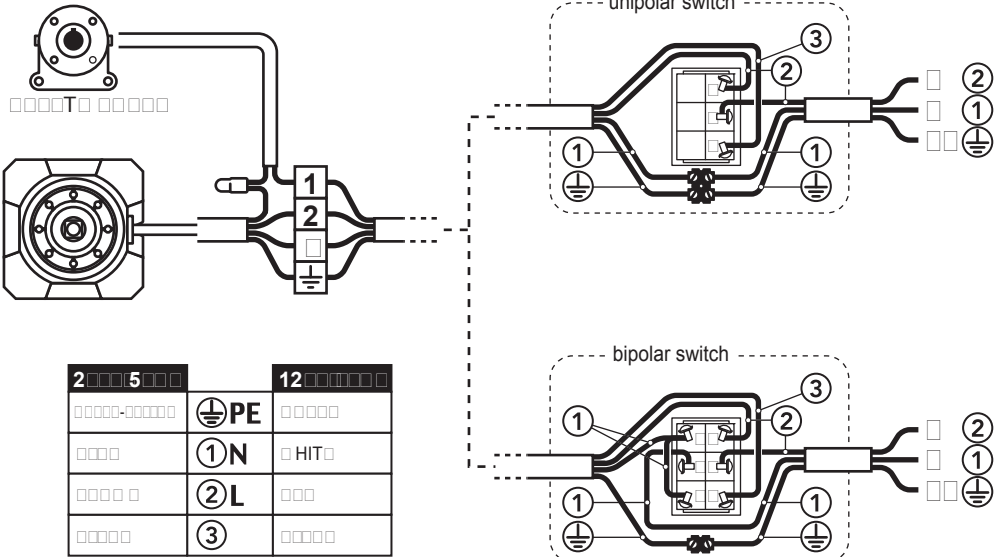

6 Identifying the limits

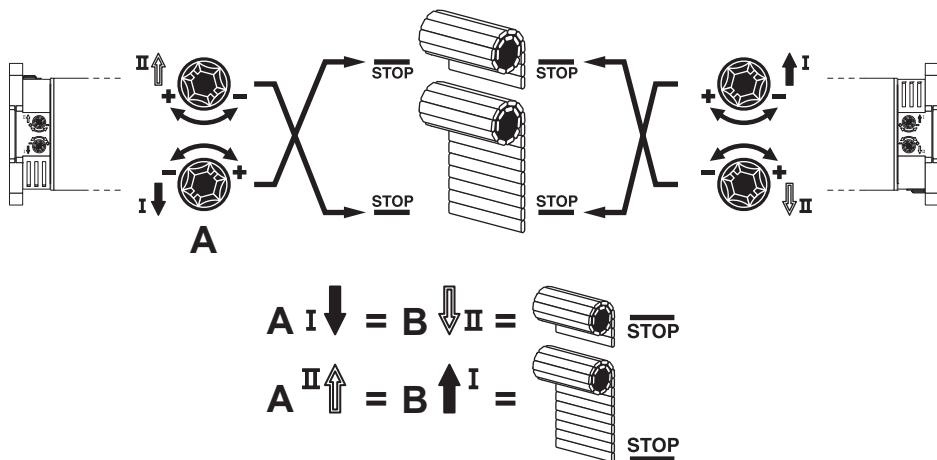
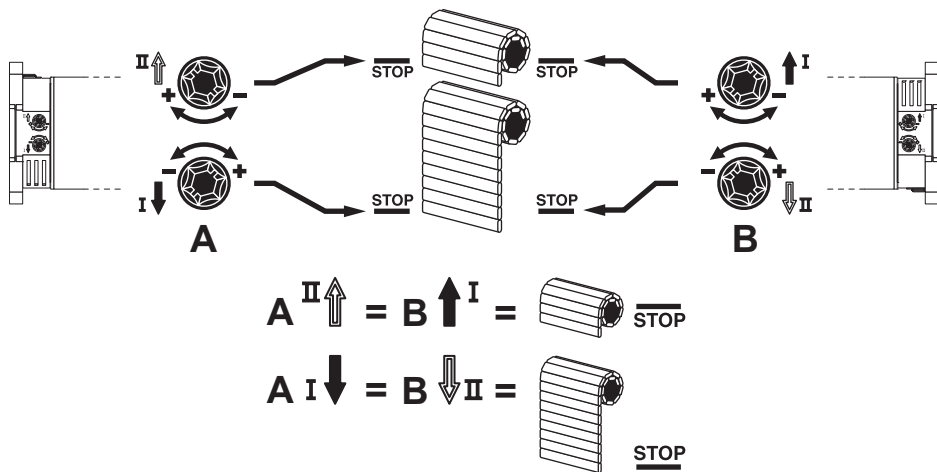

7 Adjusting the limits

1. Test

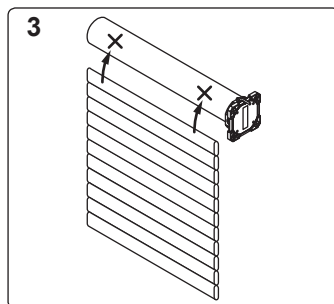
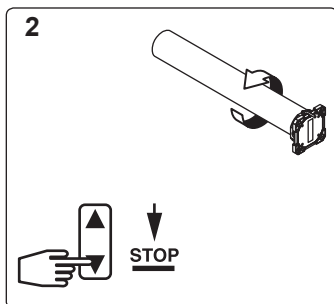
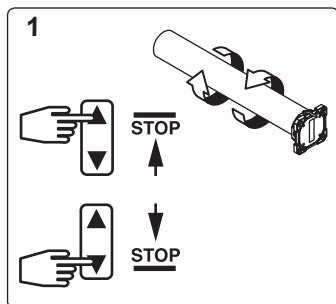

2. Set up

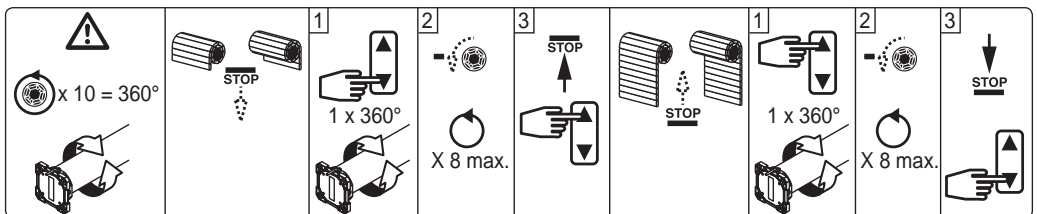
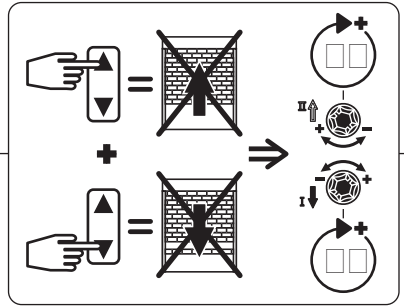
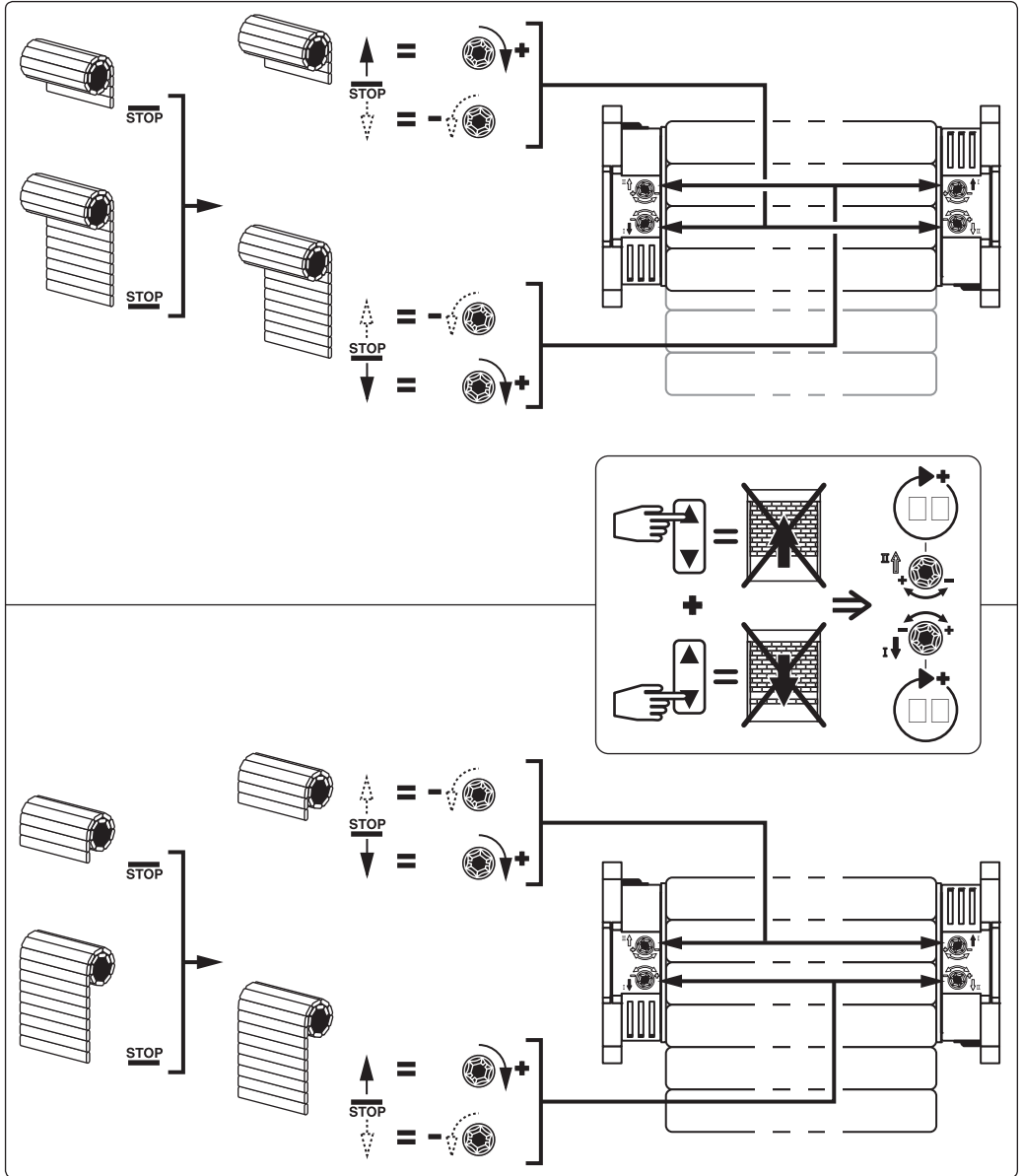



In the case of a motor with manual override system, the up direction must systematically be indicated to the end user.

If the motor is combined with a safety brake it must be connected to the motor.

The characteristics of your installation (tube, curtain weight) must comply with the recommendations given in the graphs use provided.

For any other application, please consult us.

LT80S SEL and LT80S CSI SEL

Motors with Security End Limit. See the label on the motor head.



In normal use, if the motor goes over its end-limit switch adjustment and stops on its safety limit switch, call your maintenance crew to check your installation.